

CITY COUNCIL MEETING
St. Ignace, Michigan
Monday, October 19, 2020 – 7:00 p.m.
Remote Attendance Meeting

******A G E N D A******

- 1) Call to Order
 - 2) Pledge of Allegiance
 - 3) Invocation
 - 4) Roll call
 - 5) Public Comment (3 minute limit)
 - 6) Consideration of minutes of the October 5, 2020 meetings
 - 7) Consideration of Bills
 - 8) Old Business
 - 9) New Business
-
- A. MARINA GRANT PUMP-OUT UPDATE**
 - B. ELECTION OFFICIALS**
 - C. APPROVAL OF OVERNIGHT TRAINING FOR POLICE CHIEF**
 - D. RESOLUTION CLOVERLAND EASEMENT**
 - E. FINANCIALS**
-
- 10) City Manager's Report
 - 11) Committee Reports
 - 12) Council Member Comments

**City of St. Ignace
Council Proceedings
(Unofficial)**

A Regular Meeting of the St. Ignace City Council was held on Monday, October 5, 2020, remotely via Zoom video conference.

I. CALL TO ORDER:

The meeting was called to order at 7:00 p.m. by Mayor Litzner, followed by the Pledge of Allegiance. Councilmember Clapperton gave the invocation.

Present: Councilmembers Clapperton, Fullerton, Mayor Litzner, Mayor Pro-Tem Paquin, Councilmembers Pelter, St. Louis and Tremble.

Absent: None.

Staff Present: Darcy Long, City Manager; Kyle Mulka, City Assessor; Charles Palmer, City Attorney; Andrea Insley, City Clerk/Treasurer; Lauren Yoder, Marina Director; Tony Brown, Police Chief; Alycia McKowen, Library Director; Gary Sorenson, Fire Chief.

Public Comment:

It was moved by Councilmember Fullerton, seconded by Councilmember Clapperton, to move Public Comment to the end of the meeting after Councilmember Comments.

Roll Call Vote:

Yes: Councilmember Fullerton, Mayor Litzner, Mayor Pro-Tem Paquin, Councilmembers Pelter, St. Louis, Tremble and Clapperton.

No: None.

Motion carried unanimously.

II. CONSIDERATION OF MINUTES OF THE SEPTEMBER 21, 2020 REGULAR COUNCIL MEETING:

It was moved by Councilmember St. Louis, seconded by Councilmember Tremble, to approve the minutes from September 21, 2020.

Roll Call Vote:

Yes: Mayor Litzner, Mayor Pro-Tem Paquin, Councilmembers Pelter, St. Louis, Tremble, Clapperton and Fullerton.

No: None.

Motion carried unanimously.

III. CONSIDERATION OF BILLS:

It was moved by Councilmember St. Louis, seconded by Councilmember Clapperton, to approve payment of the bills in the amount of \$ 71,470.49.

Roll Call Vote:

Yes: Mayor Pro-Tem Paquin, Councilmembers St. Louis, Tremble, Clapperton, Fullerton and Mayor Litzner.

No: Councilmember Pelter.

Motion carried six to one.

2x4 Construction Anderson, Tackman & Company PLC	Garage Door Repair/Install	\$837.22
	Final Billing 2019 Audit	\$7,096.24
Arrow Signs	Pedestrian Crossing Signs	\$675.00
Astrea	SIPD Tech Support	\$85.00
Belonga Excavating	LBE Park/Connor's Park	\$230.39
Belonga Plumbing and Heating	Water Plant/LBE Park/Lagoons/Stockbridge Lift Station	\$3,669.04
Blarney Castle Oil Company	Marina Gasoline/Diesel	\$21,576.03
Crane Engineering	Impeller and Wear Plate Heritage Lift Station	\$5,478.00
Election Source	Absent Voter Secrecy Sleeves/Voter ID Cards	\$125.13
George's Body Shop Inc	2014 Ford F350 Alignment	\$89.95
KSS Enterprises	City Hall	\$194.85
Mackinac Plumbing	Little Bear	\$147.40
Melissa Hess	LBE Painting Class	\$125.35
MGFOA MI Municipal Risk Management Authority Michigan Municipal Treasurers Assoc	2020-2021 Membership Renewal	\$120.00
	Installment #2	\$25,844.00
	Membership Renewal	\$75.00
Michigan State Police	Token Fee	\$33.00
Northern Shirt Company	LBE Uniform Shirts	\$415.60
Otis Elevator Company	Reagon Street Lift Station-WWTR	\$630.00
Paragon Laboratories	WWTR Plant	\$13.00
Printing Systems	Cemetery Deed Book	\$109.28
Seewald's Towing	SIPD - Towing 2016 Ford Taurus	\$65.00
St Ignace Chamber of Commerce	LBE Annual Membership	\$150.00
Straits Building Center	September 2020 Statement	\$332.29
Summit Companies	Annual City-Wide Fire Extinguisher Maintenance	\$2,392.32
Taylor Auto Supply Inc	DPW Shop Supplies	\$230.53
USA Blue	Reagent Supplies	\$706.58
Xylem-OI Analytical	Water plant - shipping charges	\$24.29

Total \$71,470.49

IV. OLD BUSINESS:

No old business was discussed.

V. NEW BUSINESS:

A. MHS UPDATE ON MUSEUM COLLECTION

Mayor Litzner introduced Erin Vanier, with the Michilimackinac Historical Society (MHS), who presented Council with an update of the current activities surrounding the historical tribal collections MHS is managing.

B. FIRE STATION UPDATE BY STEVEN PAQUIN

Steven Paquin, St. Ignace Building Authority Chairperson, informed Council that the new Fire Hall in its final stages of construction giving a substantial completion date of November 30, 2020. Mr. Paquin noted funds outside of the current millage that will be relied upon to fund expenses that are not part of the USDA Loan's budget, such as the Sault Tribe's 2% contributions and donations received by the public.

C. REQUEST FOR FIRE STATION EQUIPMENT PURCHASE BY GARY SORENSON, FIRE CHIEF

Fire Chief Sorenson requested Council's approval to purchase gear lockers for the new Fire Hall. Chief Sorenson provided the following bids for Council's consideration:

Gear Grid Corporation for \$6,894; Douglass Safety Systems LLC for \$6,776; West Shore Fire Inc for \$6,962; Pomasl for \$6,170.

It was Chief Sorenson's recommendation to make the purchase from Gear Grid Corp due to higher quality and the product is made in the United States.

It was moved by Councilmember Fullerton, seconded by Councilmember Pelter, to approve the purchase for the Fire Department lockers from Gear Grid Corp for \$6,894.

Roll Call Vote:

Yes: Councilmembers Pelter, St. Louis, Tremble, Clapperton, Fullerton, Mayor Litzner and Mayor Pro-Tem Paquin.

No: None.

Motion carried unanimously.

D. HALLOWEEN UPDATE ON SAFETY COVID COMPLIANCE FOR TRICK-OR-TREAT

After some discussion regarding questionable Covid-19 guidelines, Council agreed to allow Trick-or-Treating for Halloween on Saturday, October 31st from 5 p.m. to 8 p.m. Adding that residents should follow the basic safety guidelines such as social distancing, wearing masks and avoiding any direct contact when handing out candy.

E. REQUEST TO PURCHASE CITY PROPERTY NEAR BALSAM AVENUE AND MASSEY PROPERTY

City Manager Long informed Council that a resident of Balsam Street has requested to purchase a portion of City property that is next to her property lines. After some discussion regarding accessibility to other resident properties in that area, it was moved by Councilmember Pelter, seconded by Councilmember Fullerton, to begin the process of investigating the sale of the property and whether it is appropriate.

Roll Call Vote:

Yes: Councilmembers St. Louis, Tremble, Clapperton, Fullerton, Mayor Litzner,
Mayor Pro-Tem Paquin and Councilmember Pelter.

No: None.

Motion carried unanimously.

F. 2021 BUDGET SCHEDULE

City Manager Long informed Council of his plan to meet with each Department Head separately in October and scheduled a Budget Work Session with Council from 7 p.m. to 9:30 p.m. November 4th and 5th. The proposed 2021 Budget will be presented to Council the first meeting in December.

VII. CITY MANAGER'S REPORT:

City Manager Long shared with Council his recent visits to the different City departments and facilities and visits with some of the Councilmembers and City residents. He plans to continue to become more familiar by making on-site meetings and visits.

VIII. Committee Reports:

No Committee reports were given.

IX. COUNCILMEMBER COMMENTS

Mayor Pro-Tem Paquin noted local businesses had a good season even through the difficulties of the pandemic.

Councilmember St. Louis commended the local everyday front-line workers and service people.

Mayor Litzner thanked the participants and providers of the Fall Festival and Pumpkin Roll on Saturday, October 3rd.

Public Comment:

Public comment was received by several virtual participants regarding the following: virtual Council meetings, in-person Council meetings, commending front-line City and local workers, complaints of the audio of the current meeting, complaint of no return communication from the City Manager and a complaint of a matter with Police Chief Brown.

X. CLOSED SESSION

Mayor Litzner informed Council that Police Chief Brown requested that Council enter Closed Session with only the Council, City Manager Long and City Attorney Palmer present, regarding an employee issue, per Section 8(a), MCL 15.268(a).

It was moved by Councilmember Clapperton, seconded by Councilmember Pelter, to enter Closed Session regarding Police Chief Brown's request at 7:55 p.m.

Roll call vote:

Yes: Councilmembers Clapperton, Fullerton, Mayor Litzner, Mayor Pro-Tem Paquin, Councilmembers

Pelter, St. Louis and Tremble.

No: None.

Motion carried unanimously.

After Council returned from Closed Session at 9:08 p.m. it was moved by Mayor Litzner, seconded by Mayor Pro-Tem Paquin, to return to open session.

Roll call vote:

Yes: Councilmembers Fullerton, Mayor Litzner, Mayor Pro-Tem Paquin, Councilmember Pelter, St. Louis, Tremble and Clapperton.

No: None.

Motion carried unanimously.

Additionally, it was moved by Mayor Litzner, seconded by Mayor Pro-Tem Paquin, that Council authorized Councilmember Pelter to take the minutes in Closed Session, relieving City Clerk/Treasurer Insley of her duties, adding that the Closed Session minutes will be held by City Manager Long until approved at the next Council meeting.

Roll call vote:

Yes: Councilmembers Fullerton, Mayor Litzner, Mayor Pro-Tem Paquin, Councilmember Pelter, St. Louis, Tremble and Clapperton.

No: None.

Motion carried unanimously.

At this time, it was moved by Councilmember Pelter, seconded by Councilmember Tremble, that the City Council, with the support of the City Manager, determined any internal investigation of Police Chief Brown to be complete, with no findings of any significance or criminal wrongdoing.

Roll call vote:

Yes: Mayor Litzner, Mayor Pro-Tem Paquin, Councilmember Pelter, St. Louis, Tremble, Clapperton and Fullerton.

No: None.

Motion carried unanimously.

Some discussion continued among Council also recognizing the Attorney General's opinion received on this matter. It was then moved by Mayor Pro-Tem Paquin, seconded by Councilmember St. Louis, to request any internal complaints be directed to City Manager Long to determine the course of action to proceed.

Roll call vote:

Yes: Councilmembers Pelter, St. Louis, Tremble, Clapperton, Fullerton, Mayor Litzner and Mayor Pro-Tem Paquin.

No: None.

Motion carried unanimously.

XI. Adjourn:

There being no further business, the meeting adjourned at 9:17 p.m.

Connie Litzner, Mayor

Andrea Insley, City Clerk/Treasurer

PROJECT DESCRIPTION: Purchase and install an additional pump station with two additional hose stations. The new pump station will be placed next to the existing pump and connected to the existing electrical and plumbing.

Our current system is 16 years old and breaks down at the worst times. Last year it broke down during the Chicago to Mackinac Race. A second system would address this need and allow for a redundancy when one of the systems breaks down or needs service.

A second comparable system is estimated to cost about \$28,848.00.

NEEDS ACCESSMENT: The city of St. Ignace is currently paying on a marina bond that will run until 2026. All revenue sources help make the marina successful and profitable. The pump-out station has made approximately \$ 7000.00 over the last 3 years. The pump system has broken down at least once every year for the last 7 years. Fuel and pump-outs are ways to attract boaters to the marina. Some boaters come to be pumped out and then end up buying fuel and vice versa. After boaters visit our marina they are impressed with the service and accommodations and may make a return visit. Recently during an important event, the Chicago to Mackinac boat race, the pump system broke down. The two major races each year are important events for the marina. Many race boats stay at the marina and need this service. The City does not want to lose these customers. If customers are expecting to be serviced at our marina and we are unable to give them the service they need they will just continue on to the next marina.

Even though pump-outs are a small percent of our income they help attract more boaters who in turn tell other boaters how nice the facility is and learn about the many events the City of St. Ignace holds during the summer months.

PROJECT ESTIMATE:

PUMP:	\$17,885.00
LABOR:	\$ 3,000.00
ADVERTISE:	\$ 200.00
PERMITS:	\$ 500.00
ENGINEERING:	<u>\$ 3,500.00</u>
TOTAL:	\$25,085.00
CONT 15%:	<u>\$ 3,763.00</u>
PROJECT TOTAL:	\$28,848.00

PROJECT SCHEDULE:

WATERWAYS APPROVAL:	7-01-2019
ENGINEERING:	7-02-2019 to 7-19-2019
ADVERTISE:	7-22-2019 to 8-02-2019
CONTRACTS:	8-05-2019 to 8-09-2019
INSTALLATION:	8-12-2019 to 8-16-2019



Estimate

Waubashene Machine & Welding
 111 Coldwater Rd., Box 99
 Waubashene, ON, L0K 2C0
 Canada

Phone: (705) 538-1459
 Fax: (705) 538-1776
 Web: www.wmwpump.com
 www.oakleyvac.com

Date (M/D/Y)	Estimate #
3/30/2020	2671

Name / Address
St. Ignace City Marina 396 North State St. St. Ignace, MI 49781 USA

Ship To
St. Ignace City Marina 396 North State St. St. Ignace, MI 49781 USA

Customer Contact	Customer Phone	Customer Email	WMW Rep.	FOB
Lauren	(906) 298-1422	stigmarna01@gmail.com	OH	

Qty	Item	Description	U/M	Cost	Total
1	LD125P-System	Marine Pumpout System Model LD125P Note: Accessories sold separately	ea	13,996.00	13,996.00
1	LD125P-Mot I...	LD125P Option: Motorized ball valve on intake (brass)	ea	876.00	876.00
2	HA50-BV-BR	50ft Suction hose assembly with brass ball valve (1 1/2" ID)	ea	352.00	704.00
2	PAP2	Pumpout Adapter Package #2: 1x 1 1/4" + 1x 1 1/2" + 1x universal + potty wand	ea	110.00	220.00
1	Freight-LTL	Freight Note: It is the customers' responsibility to unload the equipment (i.e. fork lift). An extra fee applies if a truck with a hydraulic lift gate is required and it must be specified prior to shipment.		850.00	850.00

Terms & Conditions:
 Prices are valid for 30 days. For payment terms see below. Orders will be processed once deposit is received. All deposits are non-refundable. Shipping charges are extra. All taxes extra if applicable. All sales are final.

Sales Tax Summary		Subtotal	USD 16,646.00
Total Tax	USD 0.00	Sales Tax Total	USD 0.00
Payment Terms: 50% Deposit with order, balance due prior to shipment.		Total	USD 16,646.00

GST/HST No.

820016954

Customer Signature _____

The LD series is ideal for medium sized marinas, offering superior performance and the ability to service multiple vessels simultaneously.

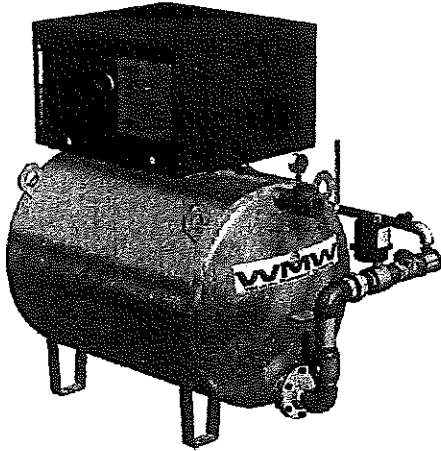

LD125P

Ideal for medium sized marinas.

Also available as model LD125C with additional compressor for vertical discharge head of up to 120ft / 36 meters.

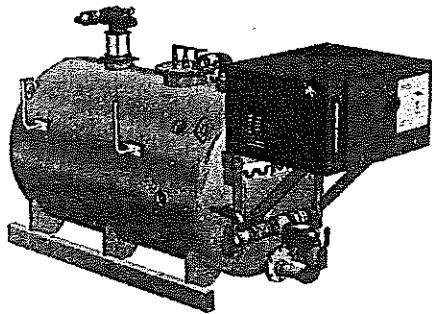

LD300P

Ideal for medium sized marinas with larger boats.

1459
0.663.1624
3.1776

@wmwpump.com
wmwpump.com

Machine & Welding
Ontario, Canada

Note: Systems are shown with optional hose hangers.



Prop Pump Location

**EMERGENCY
SHUT OFF
SWITCH**

DANGER
WARNING
DO NOT TOUCH
THIS EQUIPMENT
UNLESS YOU ARE
A QUALIFIED
PERSONNEL
ONLY

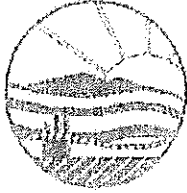

City of St. Ignace

City Clerk's Office, Andrea Insley
396 North State Street,
St. Ignace, Michigan 49781
Phone: (906) 643-8545 Fax: (906) 643-9393

THE BOARD OF ELECTION COMMISSION MEETING

The Board of Election Commission met Friday, October 16, 2020 in the office of the City Clerk/Treasurer.

Present: Alfred Feleppla; Gregory S. Cheeseman; Andrea Insley, City Clerk/Treasurer.

MOTION made by Andrea Insley, SUPPORTED by Alfred Feleppla, to select the following Election Inspectors for the General Election to be held on Tuesday, November 3, 2020.

ELECTION BOARD

Laurie Steiner, Chairperson (R)
Donna Lalonde (D)
Renee Vonderwerth (R)
Susan Paul (R)
Mary Kay Tamlyn (R)
Sherry Ceece (R)
Helen Thibault (D)
Debra Ferguson (R)
Betsy Turf (D)
Martha Sjogren (D)
Stephen Sjogren (D)
Elle Jansen (D)

The City Clerk is authorized to make substitutions in the event that any election inspector selected is not able to serve at this time.

SIGNED:

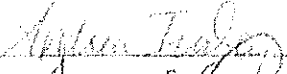



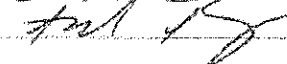

DATE: 10/16/2020

DATE: 10/16/2020

DATE: 10/16/2020

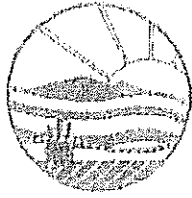

City of St. Ignace

City Clerk's Office, Andrea Insley
396 North State Street,
St. Ignace, Michigan 49781
Phone: (906) 643-8545 Fax: (906) 643-9393

THE BOARD OF ELECTION COMMISSION MEETING

The Board of Election Commission met Friday, October 16, 2020 in the office of the City Clerk/Treasurer.

Present: Alfred Feleppa; Gregory S. Cheeseman; Andrea Insley, City Clerk/Treasurer.



MOTION made by Andrea Insley, SUPPORTED by Gregory S. Cheeseman, to select the following Receiving Board Inspectors for the General Election to be held on Tuesday, November 3, 2020.

RECEIVING BOARD

Sherry Cece (R)
Donna Lalonde (D)

The City Clerk is authorized to make substitutions in the event that any election inspector selected is not able to serve at this time.

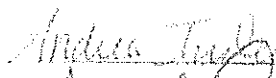
SIGNED:

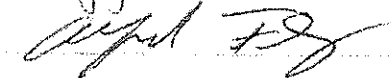
	DATE: 10/16/2020
	DATE: 10/16/2020
	DATE: 10/16/2020

PUBLIC AGENCY TRAINING COUNCIL

CONTACT PATC

ABOUT PATC

PATC PUBLISHING/BOOKSTORE

TRAINING PARTNERS



Subscribe Here!
FOLLOW PATC



**REGISTER
HERE**

TRAINING

Schedule
Courses
Options
MORE

LINKS



CLASS TRAINING SCHEDULE

SEMINAR DETAILS



Recommend

*PAST WEBINARS are for sale!
Register and pay for the past webinar, and we will send you a link.
The link gives you access for the past webinar for 24 hours.*

All webinars take place at 2 PM Eastern Time.

[Register for this Seminar](#) | [Return to Schedule](#) | [Send this page to a friend](#)

Seminar Title:

Investigating Citizen Complaints & Officer Misconduct for Supervisors

DATES: 10/26/2020 through 10/28/2020

INSTRUCTOR(S): Steven Kellams

LOCATION: Macomb Criminal Justice Training Center-East Campus PSI - 21901 Dunham Road, Clinton Township, MI 48036

HOTEL: Staybridge Suites - Detroit-Utica - Utica, MI
Contact Hotel for State Gov't Rate

COURSE REGISTRATION FEE: \$350.00 Includes all training materials, and a Certificate of Completion.

Instructor Bio

Steven Kellams is a Captain and field training expert for the Bloomington Police Department. Captain Kellams attended Indiana University from 1987 to 1991. In 1989 he graduated from the Indiana University Police Academy. In 1991 he was hired by the Bloomington Police Department and was assigned to night shift. During that time he has been a breath-test operator, bike patrol officer, field training officer, senior field training officer, and field training manager. He has also served the department as Civil Disturbance Unit Commander and Special Investigations Unit Commander. He is currently assigned as the Detective Division Commander.

In 2000 Captain Kellams was instrumental in redesigning the field training program for the Bloomington Police Department and has taught that program to hundreds of departments throughout Indiana and the United States. He has also instructed on field training issues at the national level when he presented courses at the 2002, 2009, 2010, and 2011 National Association of Field Training Officers conference in Ann Arbor, Michigan; Madison, Wisconsin; Denver, Colorado; and Phoenix, Arizona.

In 2000 Captain Kellams was elected state director for the Indiana Chapter of the National Association of Field Training Officers. In 2005 he was elected to the Executive Board of the National Association of Field Training Officers and in 2008 he was the National President of NAFTO.

In 2005 Captain Kellams was named Monroe County Officer of the Year for his work with the Bloomington Police Departments Field Training Program. Captain Kellams is a certified Indiana Law Enforcement Academy training instructor and teaches courses in Standardized Field Sobriety Tests, domestic violence, officer safety, firearms, civil disturbance, and field training.

Pre-Payment is not required to register or attend IN-PERSON seminars. Pre-payment is required for WEBINARS and ONLINE COURSES.

[CLICK HERE TO REGISTER FOR THIS SEMINAR](#)

Course Objectives

Law enforcement agencies across the United States are responsible for having an effective and professional process for investigating complaints made against its officers and to ensure that any misconduct by employees is dealt with appropriately. Often agencies will have officers specifically assigned to ensure professional standards of competence. These "Internal Affairs" or "Professional Standards" officers receive specific training on how to accomplish this task. However, with over half of the law enforcement agencies in the United States made up of fewer than 24 officers, many

SEARCH ALL PATC SITES

Custom Search

Search

CONFERENCES

[Las Vegas Winter Conference
November 30 - December 11, 2020](#)

[Gallinburg Conference
March 8-11, 2021](#)

[Las Vegas Spring Conference
March 29 - April 1, 2021](#)

PATC LEGAL ARTICLES

[View Legal Article Archive](#)

FREQUENTLY ASKED QUESTIONS

[Click Here to See Our FAQ!](#)

ARTICLE ARCHIVES

[Legal Updates](#)
[Internal Affairs](#)

[Click below to sign up for emails and brochures!](#)

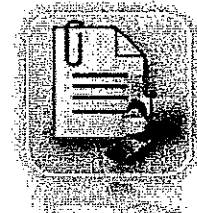
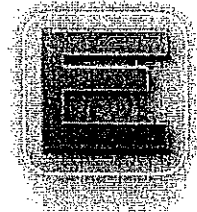

agencies lack the resources for these investigative specialists. Therefore, the duty of investigating these types of complaints is left to the shift supervisor. Misconduct investigations are unlike most other investigations and require a fact-finding approach and transparency in order to retain the public's confidence and trust. An agency must demonstrate to the public and its members that only the highest ethical standards of law enforcement will be practiced by the agency and that the investigation of complaints follow established professional standards. Immediate and proper intervention of potential employee performance or misconduct incidents, at the appropriate level, serves to promote morale within the agency and promotes positive interactions and support of the community.



Students will learn:

- the importance of ethical standards for persons assigned to conduct internal investigations and the core values associated with the proper handling of all internal investigations.
- about the impact of internal investigations on officer's conduct and ethical decision-making.
- to identify the difference between performance issues, policy issues, and serious misconduct as well as the supervisor's role in handling such incidents.
- the necessary steps regarding an internal investigation and relevant case law involving the interviews, investigations, and searches of employees.

[Register for this Seminar](#) | [Return to Schedule](#) | [Send this page to a friend](#)

Public Agency Training Council - 5235 Decatur Blvd - Indianapolis, IN 46241 - 800.365.0119

[About PATC](#) | [PATC Publishing/Bookstore](#) | [Training Partners](#) | [E-Newsletter](#) | [Contact Us](#) | [Home](#) | [Site Terms of Use Policy](#)

**Thank you for registering for a PATC Seminar**

5235 Decatur Blvd Indianapolis, IN 46241 |
P: 800.365.0119 | F: 317.821.5096 | www.PATC.com

*** This is not an Invoice. ***
Official confirmation will be sent via email to
stignacepd@lighthouse.net within two business days.



SEMINAR INFORMATION:

Seminar Title: Investigating Citizen Complaints & Officer Misconduct for Supervisors

Seminar ID: 16941

Dates: 10/26/2020 through 10/28/2020

Training Fee Per Attendee: \$350.00 **Payment Method:** invoice

Seminar Location: Macomb Criminal Justice Training Center-East Campus PSI
21901 Dunham Road
Clinton Township, MI 48036

Recommended Hotel: Staybridge Suites - Detroit-Utica
46155 Utica Park Boulevard
Utica, MI 48315

Contact Hotel for State Gov't Rate

REGISTRATION INFORMATION:

Agency Name: St. Ignace Police Department

Invoice To Attention: Chief Tony Brown

Address: 396 N. State St

City: Saint Ignace

State: MI **ZIP:** 49781

Contact Email Address: stignacepd@lighthouse.net

Phone: 906-643-6077 **FAX:** 906-643-8614

Registered Attendees: Tony Brown

Visit www.patc.com/training/registrations.php for more important information about PATC registrations.

**RESOLUTION
OF THE CITY OF ST. IGNACE**

WHEREAS it is in the best interest of the City of St. Ignace to grant an easement, on property known as TAX# 052-007-025-10, to Cloverland Electric Cooperative, Inc. for the purpose of providing electric service to the City of St. Ignace Firehall.

RESOLVED that the the City of St. Ignace has approved the grant of this easement.

RESOLVED that the City of St. Ignace has authorized _____,
to carry out the grant of this easement. *(name & title)*

WHEREAS said easement was executed by _____,
on _____, 2020.

By _____ Date _____
*

By _____ Date _____
*

By _____ Date _____
*

By _____ Date _____
*

By _____ Date _____
*

By _____ Date _____
*

**Name and title*

RIGHT-OF-WAY EASEMENT

KNOW ALL MEN BY THESE PRESENTS, that the *City of St. Ignace*

Whose address is: **396 North State Street, St. Ignace, Michigan 49781**

Grantors, for no monetary consideration, do hereby grant unto CLOVERLAND ELECTRIC COOPERATIVE, INC., a Michigan Corporation, 2916 West M-28, Dafter, Michigan 49724, Grantee, its successors, assigns, lessees, licenses, and agents, the perpetual right to enter upon the lands of the undersigned, situated in the City of **St. Ignace**, County of **Mackinac**, State of Michigan, and more particularly described as follows:

A 300 foot by 300 foot piece of land located in the Northeast corner of the following described land: That part of the Private Claims No. 7 and 8, City of St. Ignace, Mackinac County, Michigan, lying Westerly of the West line of Chambers Street and Southerly of the South line of Marley Street. Contains 2 acres, more or less. (TAX# 052-007-025-10)

This easement is limited to eight feet each side of the center of the underground electric line and/or fifteen feet each side of the center of the overhead electric line to provide electric service, on the above-described parcel, including the right to extend electric facilities along roads, drives, property lines or other reasonable routes to adjacent parcels; AND ALSO:

It is the intent to provide easement for the proposed electric facilities located on the above-described parcel, said line route will be in a Northwesterly, thence Westerly direction.

And with the right to lay, remove, patrol, locate, relocate, construct, reconstruct, repair, replace, extend, enlarge, improve, operate and maintain on the above-described land and/or in or upon all streets, roads or highways abutting said lands, an electric distribution line or system, and/or Cooperative communications system, including all related equipment above or below ground, other fixtures and appurtenances for the purpose of transmitting and distributing electricity on, in, under, through or across and to license, permit, or otherwise agree to the joint use or occupancy of the line or system by any person, association or corporation. Said equipment, other fixtures and appurtenances shall be constructed at such locations along said route as may be necessary.

Also conveying the right to cut, trim, remove, destroy, treat, or otherwise control trees, roots, brush, shrubbery or other vegetation located within eight (8) feet for underground / fifteen (15) feet for overhead of the center line of said line or system, or that may interfere with, hazardous to, or threaten to endanger the construction, operation and maintenance of said line or system. If it is necessary to treat the vegetation, said treatment is limited to the use of herbicide for stump treatment and/or basal application to trees less than three inches in diameter.

The undersigned agree that all poles, wires and other facilities, installed on the above-described lands at the Cooperative's expense, shall remain the property of the Cooperative, removable at the option of the Cooperative.

Grantor hereby agrees that no buildings or other structures will be placed over or under said facilities and that no buildings or other structures will be placed within such close proximity to any of said facilities as to interfere with or in the opinion of Grantee, threaten to interfere with, the construction, operation or maintenance of said electrical and/or Cooperative communication facilities.

Grantor covenants and agrees that the average ground elevation within eight (8) feet for underground/ fifteen (15) feet for overhead, of any such electrical and/or Cooperative communications facility may be maintained by the Grantee at a level not to exceed twelve (12) inches above or six (6) inches below that level established at the time of installation of said facilities, fixtures and appurtenances.

Grantor further covenants and agrees for itself and its assigns that no changes or alterations will be made by it or its assigns beyond the limits above stated in the ground surface elevations in the areas of such underground facilities, transformer pads, and/or poles as above specified without the written consent of the Grantee. These covenants shall run with the land.

It is further agreed that non-use or a limited use of the easement herein granted shall not prevent Grantee from later making use of this easement to the full extent herein authorized.

IN WITNESS WHEREOF, the undersigned have set their hands and seals this _____ day of _____, 20_____.

City of St. Ignace:

x _____ (L.S.)
*

STATE OF _____)
COUNTY OF _____)

On this _____ day of _____, 20_____, before me, a Notary Public in and for said County, personally appeared _____, to me known to be the person(s) described in and who executed the within instrument and who duly acknowledged the same to be **his/her/their** free act and deed.

Notary Public _____
*

in and for _____ County, _____.

My Commission Expires: _____

**Type or print names under signatures*

Drafted By: Johanna Wiltfong
Cloverland Electric Cooperative
2916 West M-28
Dafter, Michigan 49724
2019

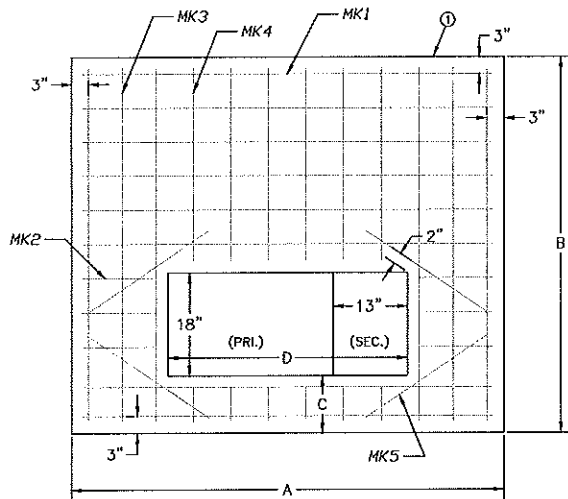

PAD	3-PHASE TRANSF. KVA	DIMENSIONS IN INCHES					REINFORCING BARS				
		A	B	C	D	E	MK1	MK2	MK3	MK4	MK5
#1	75, 112.5, 150, 225, 300, 500	76	66	10	42	6	8 #4 70"	6 #4 10"	6 #4 61"	6 #4 32"	4 #4 26"
#2	750, 1000, 1500, 2500	104	100	10	54	8	13 #4 98"	6 #4 19"	8 #4 94"	8 #4 66"	4 #4 29"

Clearance from pad to structures/obstructions	Front	Back	Sides
	10'	8'	3'

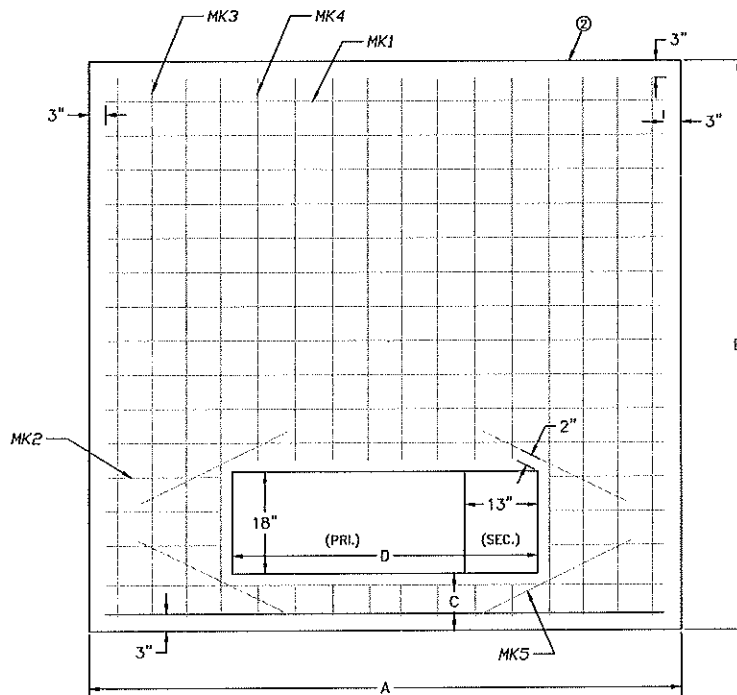
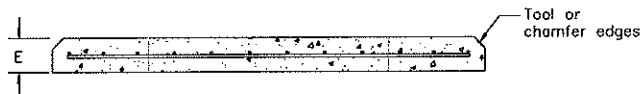

NOTES:

1. Concrete testing, 3000 PSI; 4% to 6% entrained air; $\frac{3}{4}$ " maximum size aggregate.
2. Rebar steel, ATSM-A615 Grade 60, Place approx. 6" O.C. each way and securely tied together.
3. Minimum concrete cover over reinforcing steel 2" unless noted.
4. Wood float finish, leaving no depressions.

THREE PHASE TRANSFORMER
CONCRETE PAD GUIDE

Last Updated

MAR 2016



Cloverland
ELECTRIC COOPERATIVE

UM1-6C